

# Operator's Instruction Manual

# Grinders / Surfacers

Gasoline • Electric • Propane



**SINGLE DISC MODEL  
S-EC**



**DUAL DISC MODEL  
2-EC, 2-GC, 2GC-P**



**FOUR DISC MODEL  
411-E, 411-G, 411GP**

**Manual - Portable**



100 Thomas Johnson Drive, Frederick, MD 21702-4600 USA  
Phone (301) 663-1600 • 1-800-638-3326  
Fax (301) 663-1607 • 1-800-447-3326  
Website: [www.edcoinc.com](http://www.edcoinc.com) • Email: [sales@edcoinc.com](mailto:sales@edcoinc.com)

Printed in USA  
tw ©2003

## READ AND UNDERSTAND THE OPERATORS INSTRUCTION MANUAL *THOROUGHLY* BEFORE ATTEMPTING TO OPERATE THIS EQUIPMENT.



**Death or serious injury could occur if this machine is used improperly.**



### SAFETY MESSAGES

- Safety Instructions are preceded by a graphic alert symbol of DANGER, WARNING, or CAUTION.



Indicates an imminent hazard which, if not avoided, will result in death or serious injury.



Indicates an imminent hazard which, if not avoided, can result in death or serious injury.



Indicates hazards which, if not avoided, could result in serious injury and or damage to the equipment.

### GASOLINE/PROPANE POWERED EQUIPMENT



- Engine exhaust from this product contains chemicals known to the State of California to cause cancer, birth defects or other reproductive harm.



- Gasoline is extremely flammable and poisonous. It should only be dispensed in well ventilated areas, and with a cool engine.

- Small gasoline engines produce high concentrations of carbon monoxide (CO) example: a 5 HP 4 cycle engine operation in an enclosed 100,000 cu. ft. area with only one change of air per hour is capable of providing deadly concentrations of CO in less than fifteen minutes. Five changes of air in the same area will produce noxious fumes in less than 30 minutes. Gasoline or propane powered equipment should not be used in enclosed or partially enclosed areas. Symptoms of CO poisoning include, headache, nausea, weakness, dizziness, visual problems and loss of consciousness. If symptoms occur - get into fresh air and seek medical attention immediately.

### ELECTRICAL POWERED EQUIPMENT



Extreme care must be taken when operating electric models with water present: Ensure power cord is properly grounded, is attached to a Ground-Fault-Interrupter (GFI) outlet, and is undamaged.

- Check all electrical cables - be sure connections are tight and cable is continuous and in good condition. Be sure cable is correctly rated for both the operating current and voltage of this equipment.
- Improper connection of the equipment-grounding conductor can result in a risk of electric shock. Check with qualified electrician or service person if there is any doubt as to whether the outlet is properly grounded. Adhere to all local codes and ordinances.
- NOTE:** In the event of a malfunction or breakdown, grounding provides a path of least resistance for the electric current to dissipate. The motor is equipped with a grounded plug and must be connected to an outlet that is properly installed and properly grounded. **DO NOT** modify the plug provided on the motor. If the plug does not fit the outlet have a qualified electrician install the proper receptacle.
- Switch motor OFF **before** disconnecting power.

- Do not disconnect power by pulling cord. To disconnect, grasp the plug, not the cord.
- Unplug power cord at the machine when not in use and before servicing.

### GENERAL INSTRUCTIONS

- Equipment should only be operated by trained personnel in good physical condition and mental health (not fatigued). The operator and maintenance personnel must be physically able to handle the bulk weight and power of this equipment.
- This is a one person tool. Maintain a safe operating distance to other personnel. It is the **operators' responsibility** to keep other people (workers, pedestrians, bystanders, etc.) away during operation. Block off the work area in all directions with roping, safety netting, etc. for a safe distance. Failure to do so may result in others being injured by flying debris or exposing them to harmful dust and noise.
- This equipment is intended for commercial use only.
- For the operator's safety and the safety of others, always keep all guards in place during operation.
- Never let equipment run unattended.



- Personal Protection Equipment and proper safety attire must be worn when operating this machinery. The operator must wear approved safety equipment appropriate for the job such as hard hat and safety shoes when conditions require. Hearing protection **MUST** be used (operational noise levels of this equipment may exceed 90db). Eye protection **MUST** be worn at all times.



Keep body parts and loose clothing away from moving parts. Failure to do so could result in dismemberment or death.

- Do not modify the machine.
- Stop motor/engine when adjusting or servicing this equipment.



Maintain a safe operating distance from flammable materials. Sparks from the cutting-action of this machine can ignite flammable materials or vapors.

### DUST WARNING



Some dust created by power sanding, sawing, grinding, drilling, and other construction activities contains chemicals known to cause cancer, birth defects, or other reproductive harm.

Some examples of these chemicals are:

- Lead from lead-based paints, and
- Crystalline silica from bricks and concrete and other masonry products.

Your risk of exposure to these chemicals varies depending on how often you do this type of work. To reduce your risk: work in a well ventilated area, use a dust control system, such as an industrial-style vacuum, and wear approved personal safety equipment, such as a dust/particle respirator designed to filter out microscopic particles.

# SPECIFICATIONS

<u>Section</u>	<u>Table of Contents</u>	<u>Page Number</u>
Safety/Warnings.....		2
Specifications/Table of Contents.....		3
Operating Controls.....		4
Operating Instructions.....		6-7
Procedure for adjusting or replacing drive belts.....		8
Procedure for installing and removing accessories.....		9
Instructions for changing accessories.....		10
Three types of accessories.....		11
Silabide pad information.....		11
Grinder/Surfacer accessories.....		12
Lubricating flange bearings.....		13
Attaching a vacuum.....		13
Maintenance Instructions.....		14
Maintenance Schedule.....		15
Limited Equipment Warranty.....		Back Page

Note:  
All dimensions and weights are for **reference only** and subject to change at any time.

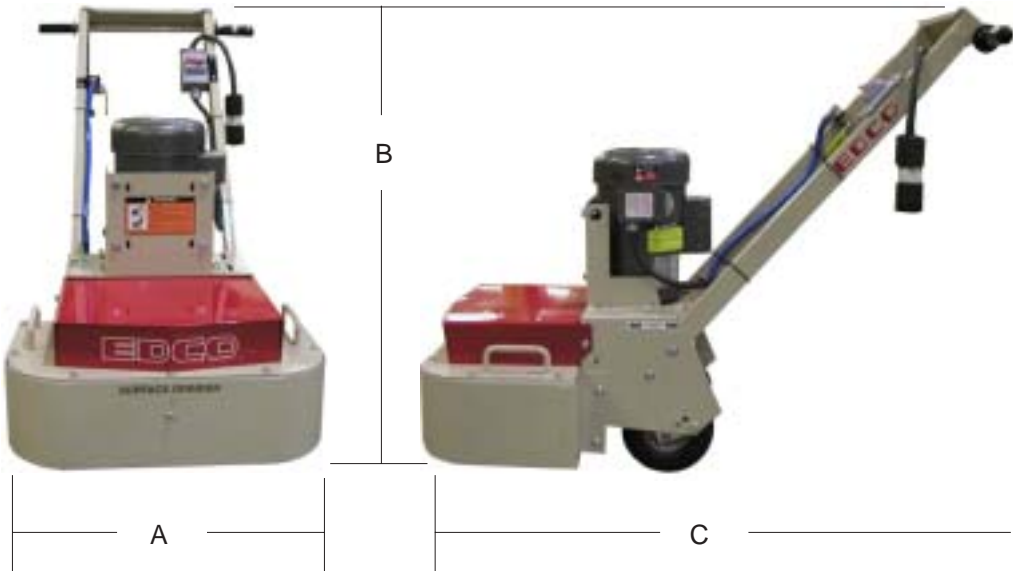

2-EC Shown

**Figure 1**

**HOW TO ORDER REPAIR PARTS**

To insure product safety and reliability, always use genuine EDCO replacement parts when making repairs to the equipment.

When ordering parts, please specify the MODEL and SERIAL NUMBER of the machine as given on the NAMEPLATE. In addition, give part number, description and quantity as listed on the parts list.

Please note: Due to improvements and changes in the equipment the illustrations shown may be different from the actual machine.

Toll Free: Phone 1-800-638-3326 • Fax 1-800-447-3326

	S-EC	2-EC	2- GC	411
"A"	21 1/4"	24 1/2"	24 1/2"	40"
"B"	37"	43"	43"	41"
"C"	42"	44"	44"	48"
-	--	--	--	--
-	--	--	--	--
Weight	174 lbs.	227 lbs.	240 lbs.	435 lbs.
-	--	--	--	--



100 Thomas Johnson Drive, Frederick, MD 21702-4600 USA  
 Phone (301) 663-1600 • 1-800-638-3326  
 Fax (301) 663-1607 • 1-800-447-3326  
 Website: www.edcoinc.com • Email: sales@edcoinc.com

# Operating Controls

**Please Note:**

Controls shown are for the model indicated.

The location of these controls may vary on the different models.

Due to improvements and changes in the equipment, the illustration shown may vary from the actual machine.

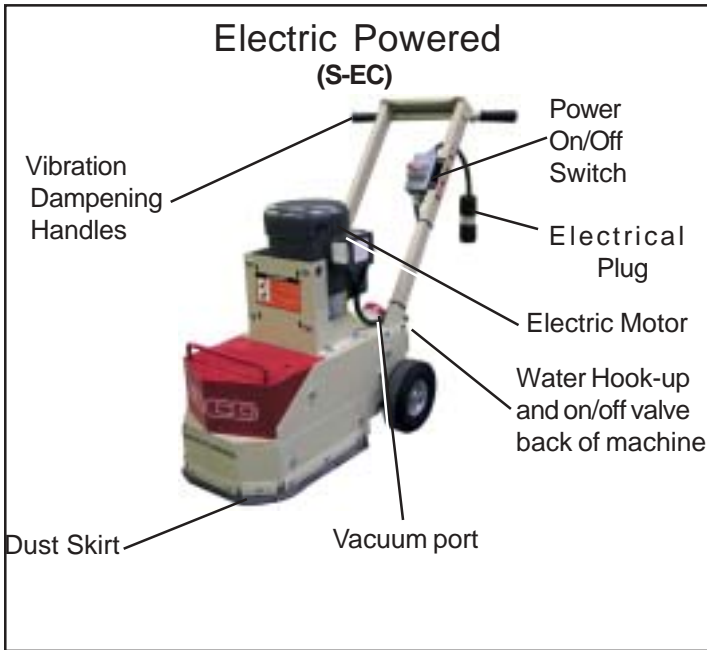

**Figure 2**

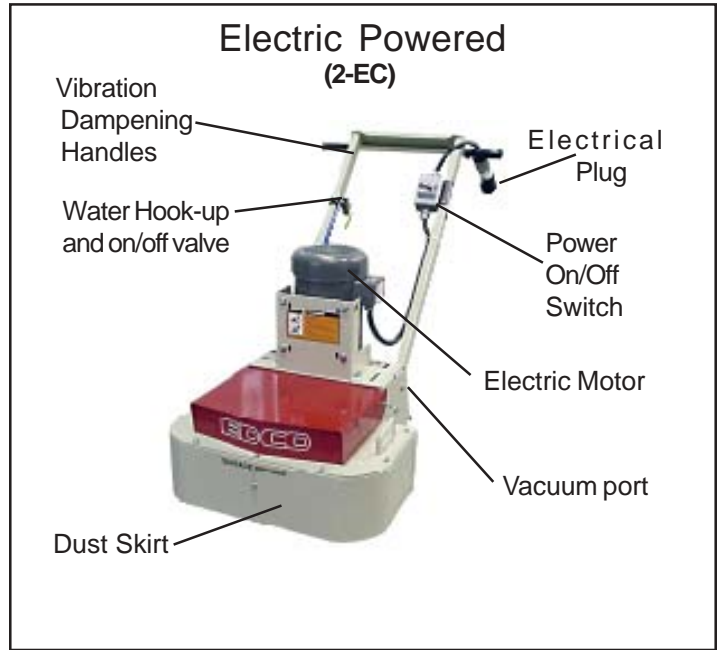

**Figure 3**



NOTE: Operating controls are the same for the gasoline and propane models.

**Figure 4**



NOTE: Operating controls are the same for the gasoline and propane models.

**Figure 5**



# Propane System

Red Arrow  
Pointing "Up"  
Tank Bottom

#1 Main Power  
Adjustment

Vapor Hose  
(Low Pressure)



Propane Tank  
(20 lb horizontal)

High Pressure  
LP Hose

#2 Idle Mixture  
Screw

Dry-Gas  
Regulator

High Pressure  
LP Hose

Vacuum  
Hose

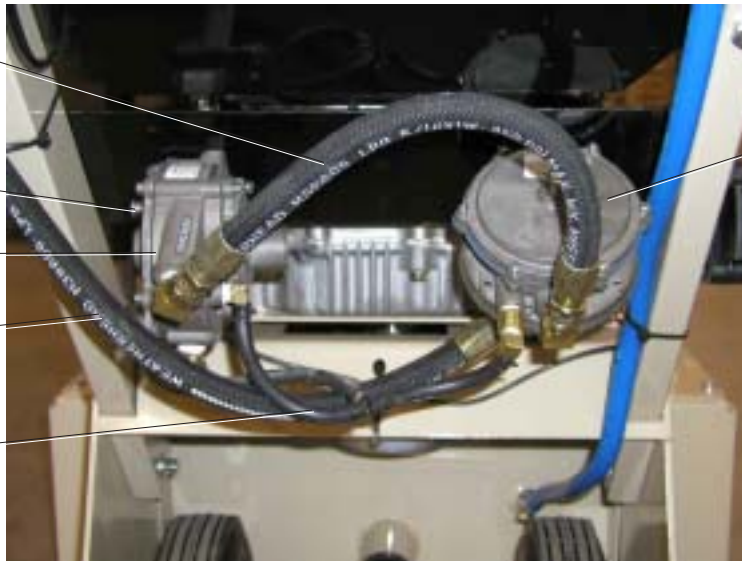

Vacuum  
Fuellock - Filter

Main Fuel  
Valve

Propane Tank  
(20 lb horizontal)

Locating  
Hole



**Propane Tank (P/N 15130)  
Horizontal Mount (Vapor  
Withdrawal)**

**NOTE:** The Red arrow on the tank will be pointing "up". The locating hole is oriented under the gauge as viewed in the photo on the left.

Fuel Gauge



# Operating Instructions



- Read and understand all operating instructions before operating this equipment. Death or serious injury can result if this machine is used improperly.
- Concrete grinders are designed to be used to grind flat horizontal concrete slabs using EDCO approved accessories.
- The machines are equipped with gasoline/propane engines and electric motors.
- They are designed to be controlled by a single operator from a position at the rear of the machine.
- When operating equipment maintain a safe distance from other personnel in the area.

**Be sure to read the complete instructions supplied with your machine.**

**IMPORTANT:** Perform Pre-Start Check.

- Visually inspect the equipment for wear or damage.
- Be sure all guards are in place and functioning properly. Do not operate unless all guards are in place and secure.
- Perform all daily maintenance.
- Check to be sure water tubes are functioning properly if performing wet-grinding operations.
- Inspect accessories - Be sure the correct accessory is installed properly on the machine, mounting arrangement and its intended use.
- Check accessories for damage (see figure 6, below), the type of wear or damage will vary with the type of accessory.
- Inspect work area to determine the presence and location of deck inserts, pipes, columns and objects protruding from the slab surface so that they may be avoided during the grinding operation.
- **FOR WET GRINDING:** Attach the water supply. A flow rate of approximately 1/2 gallon per minute is recommended.

## EXAMPLE OF SEVERELY WORN DYMA-SERT

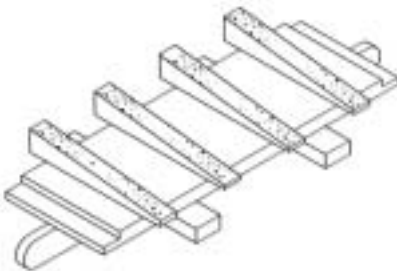

The above is an example of a DYMA-SERT that has not been rotated after every four hours of use. To get maximum life out of a DYMA-SERT they should be rotated 180° every four hours of use.

## EXAMPLE OF AN EVENLY WORN DYMA-SERT

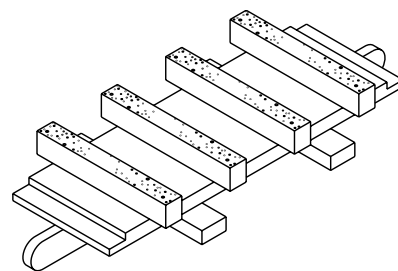

The above is an example of a DYMA-SERT that has been rotated after every four hours of use, as you can see the wear is even across all segments.

**Figure 6**

# Operating Instructions

- **BEFORE STARTING THE ENGINE:** Raise the front of the machine clear of the working surface.
- **START ENGINE AND ALLOW IT TO REACH OPERATING SPEED.** Position the grinder at the starting point. Bring the engine to full speed. Lower the machine onto the slab surface. Use a slow sweeping motion from left right and back continuously, and do not force the machine into the work, the engine or motor should not strain when grinding.
- **WHEN WET GRINDING:** Water is required. Attach the water hose to the water hook-up valve. Use the valve to control the flow of water.
- **FOR DRY GRINDING:** Provide a respirator and dust control system.
- **FOR GASOLINE MODELS:** Put the engine stop switch in the "RUN" position. Consult the engine manufacturers operating instructions and follow the directions for starting and breaking in the engine.
- **TO STOP THE MACHINE:** Stop forward motion. On gasoline models push the throttle to idle. Turn ignition or power switch off and let the engine come to a complete stop. Turn off the water supply.
- **WHEN MANEUVERING THE GRINDER:** Tilt grinder back enough so it does not strike the slab surface. Damage to accessories may occur with inadvertent contact with the slab.
- **DO NOT FORCE GRINDER WHILE GRINDING.**
- **IF THE POWER SOURCE FAILS:** Raise the grinder off of the floor. Disconnect the power source (i.e. the spark plug wire on a gasoline engine). Inspect the accessories for damage. Replace damaged (or questionable) accessories immediately.
- **WHEN TRANSPORTING THE GRINDER:** Disconnect the power source before lifting or removing any guard. See the directions for changing accessories on **page 9**.
- **WHEN HOISTING OR LIFTING A GRINDER :** Always inspect frame and attaching hardware for damage **before** lifting. Use proper safe hoisting and lifting techniques and hardware.



## PROCEDURE FOR ADJUSTING OR REPLACING DRIVE BELT



NOTE: The following applies to all machines. They all adjust in the same manner.

To adjust the drive belt loosen four (4) cap screws securing the motor mount to the frame.

Slide the motor mount to the rear of the machine to increase belt tension.

Tighten the four (4) cap screws loosened earlier maintaining pressure on the motor mount to prevent loosening.

To replace the belt, remove the (red) hood by removing two (2) cap screws, one on each side of the machine.



Loosen the four (4) cap screws as in the first step and slide the motor mount all the way forward.

Remove the belt from the motor and pinion shaft sheaves as shown in the photo on the left.

Reverse the previous step to install new belt. Slide motor mount towards the rear of the machine and adjust belt tension, tighten all four (4) cap screws as explained above. Replace red hood and tighten bolts.

New belts should be retensioned after grinder has been used for 4 hours.

## PROCEDURE FOR INSTALLING AND REMOVING ACCESSORIES

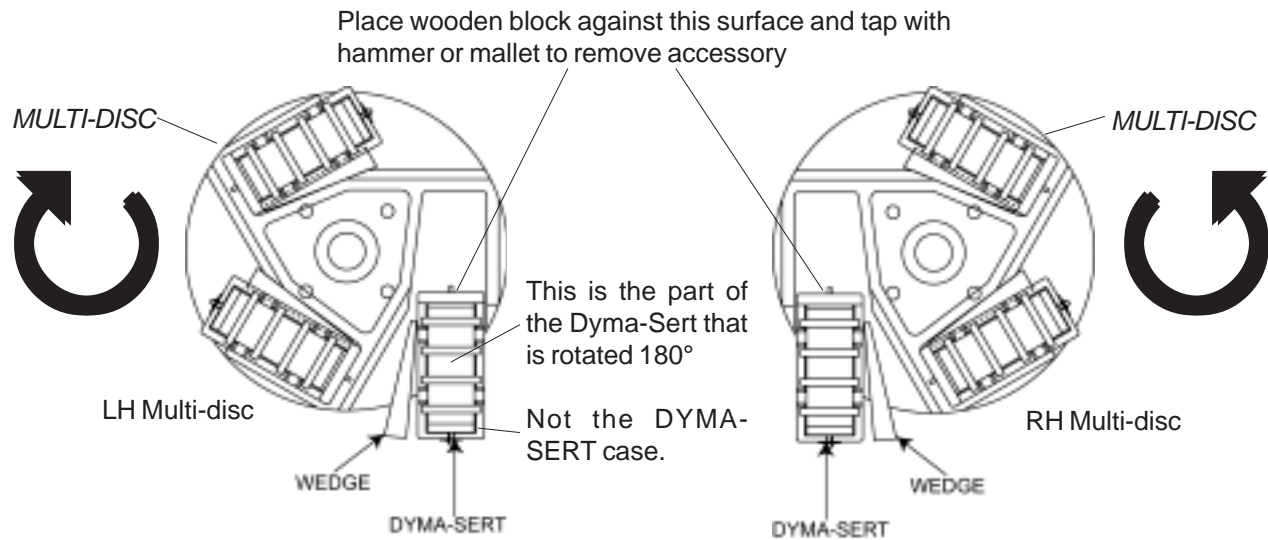

To install an accessory, there are several different types but all install in the same manner, use a brass rod or similar malleable material to drive the wooden wedge into place as shown in the above and below illustrations, note on which side of the accessory the wooden wedge is positioned (near center of disc). Never mix worn or used accessories with new ones. It will cause vibration and an uneven work surface. Replace accessories in complete sets, never mix sets.

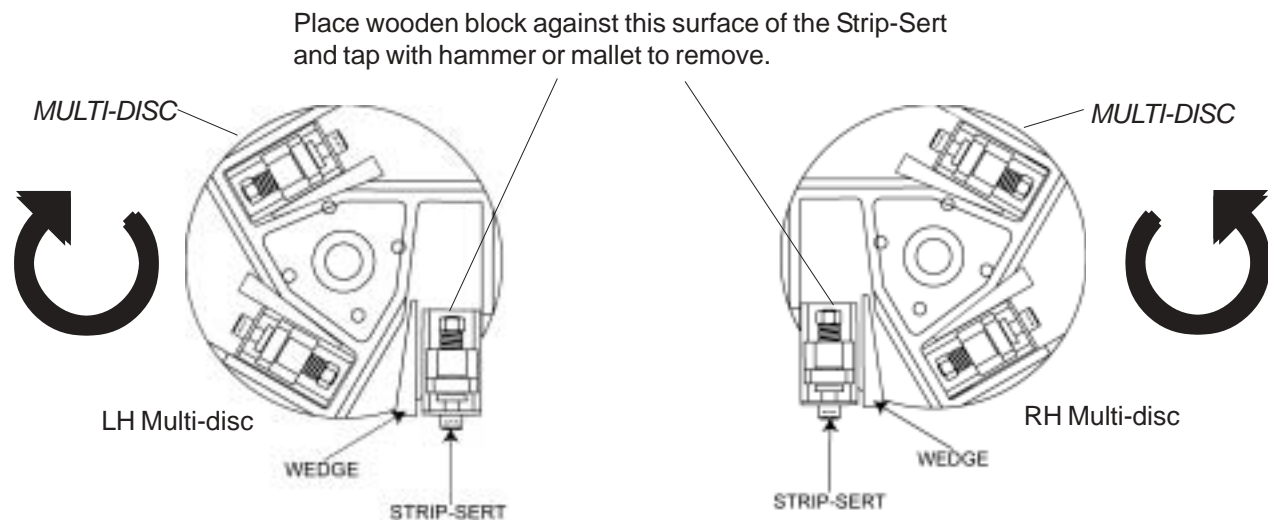

To remove an accessory, there are several different types, all are removed in the same manner, use a wooden block as explained in the above illustration. Never hammer directly on any accessory, damage to the self adjusting system will result and the accessory will have to be replaced.

**NOTE: THE ABOVE ILLUSTRATIONS ARE VIEWING THE MACHINE FROM THE FRONT BOTTOM. NOTE THE DIRECTION OF ROTATION AND *MULTI-DISC* STYLE. IF DISCS ARE REPLACED AND INSERTS FALL OUT WHEN BEING USED THE DISCS HAVE BEEN INSTALLED INCORRECTLY.**



## INSTRUCTIONS FOR CHANGING ACCESSORIES

1.



Disconnect the machine from the power source before performing any work on the equipment. To disconnect the power source remove the spark plug lead on gasoline and propane models or unplug the electrical models at the grinder.

2. Tip Grinder back on the handle until handle remains in contact with the slab. **NOTE: FOR GASOLINE MODELS, TAKE CARE THAT GASOLINE OR OIL DOES NOT SPILL FROM THE ENGINE, Turn gasoline cutoff valve off.** Brace securely or have someone hold the handle against the slab. The grinding discs will be visible and accessible for inspection and installation of accessory items.

3. Installing Multi-disc assemblies (for use with scarifiers, silabide pads, wire brushes and Dyma-Serts). The multi-discs are designed as lefthand (LH) or righthand (RH) depending on the direction of rotation: the LH is on the left side (clockwise) and RH is on the right side (counter clockwise) as viewed from the bottom side of the machine. The single disc grinders use the RH disc. **NOTE: Multi-Discs come standard with the EDCO grinders in this manual. The multi-disc assemblies use a 3/8" dia. x 2" long roll pin to attach them to the shaft(s) under the grinder (refer to page 11).**

4. When installing the surfacer disc assemblies instead of the Multi-disc assemblies (refer to figure 7). The discs are triangular and must be allowed to pass each other without colliding.

5. Installing grinding stones. Grinding stones are used on the multi-disc assembly. A total of 3 stones are used with each multi-disc and are held in place with a hardwood wedge. The wedges are placed on the inside of the stone (refer to page 10). Use a second wedge and hammer or mallet to drive the wedge securely into place.

6. Installing wire brushes. The steel wire brushes are used on the multi-disc assembly (3 per multi-disc). They are held in place with a hardwood wedge driven in on the inside of the brush toward the center of the disc, refer to the previous page. All accessories are held in place in the same manner.

7. Installing Scarifiers. The scarifier assemblies consist of disposable scarifiers and a reusable scarifier case. The case is held into the multi-disc assembly with a hardwood wedge driven in on the inside of the case toward the center of the disc, refer to the previous page. All inserts are held in place in the same manner.

The scarifiers can be added or removed from the case without disturbing the case. One end of the scarifier is short and has a tab. The tab is simply inserted under the lip of the case and the other end is pressed into the spring loaded slot and seated firmly. Refer to diagram on page 11.

To remove the scarifier from the case, simply pry the rounded end of the frame out of the spring loaded slot.

**Installing Dyma-Serts:** The Dyma-Sert assembly consists of a disposable Dyma-Sert cutter, a shock absorbing rubber block, and a reusable Dyma-Sert case. Three Dyma-Sert assemblies are used on each multi-disc. The case is held on the multi-disc assembly by using a hardwood wedges driven in on the inside of the case. Refer to diagram on page 11.

The Dyma-Serts can be added or removed from the reusable case. One end of the Dyma-Sert has a lip. The lip is simply inserted under the lip of the case and the other end is pressed into the spring loaded slot at the other end and seated firmly. Refer to page 11.

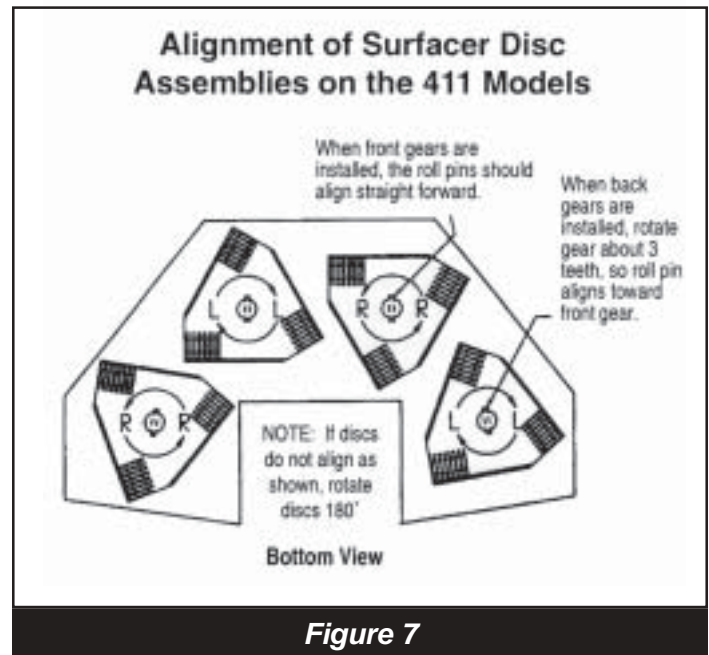

### Multi-disc Assembly

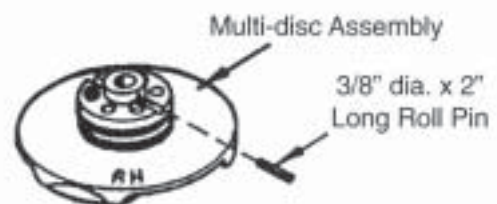

## THREE TYPES OF ACCESSORIES

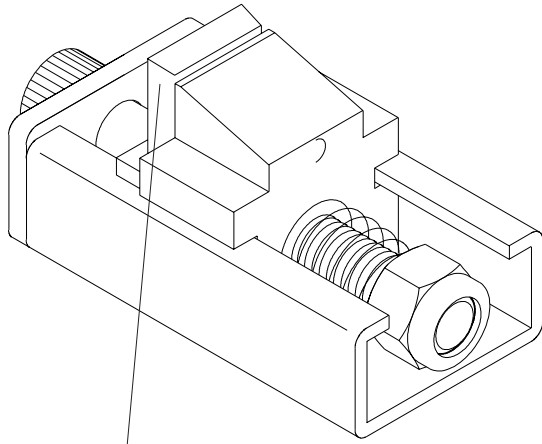

This is a STRIP-SERT, rotate this blade to expose a new cutting surface. There are four (4) cutting surfaces on each blade.

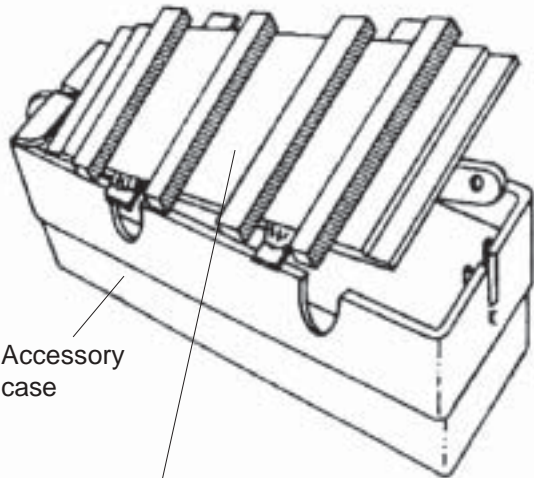

Accessory case

This is a DYMA-SERT, rotate the DYMA-SERT only, not the case.

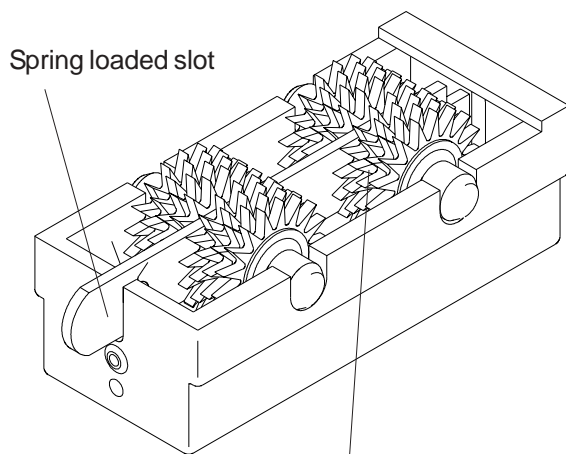

This is a Scarifier and does not require rotation.

## SILABIDE PAD INSTALLATION

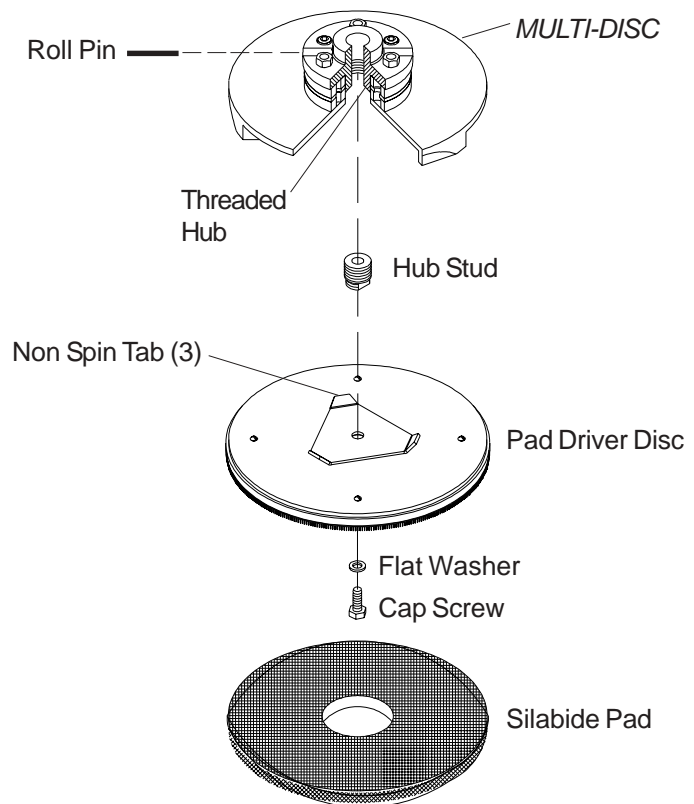

Exploded view of Silabide Pad assembly.

**Installing Silabide Pads:** Install Hub Stud - one in each threaded hub, this is a permanent installation and the stud need not be removed when using the surfacer as a grinder or scarifier.

### CAUTION

Be sure that the end of the stud, when fully threaded into hub, does not project past web of multi-disc assembly. Your surfacer is now ready to receive the PAD DRIVER DISC anytime the need arises.

**To install Pad Driver Disc:** Position PAD DRIVER DISC against the web of the multi-disc, be sure "non-spin-tabs" are in place (see illustration) in the center casting web to prevent disc from turning loose. Be sure Pad Driver Disc is positioned flat against the casting. Insert capscrew with flat washer through hole in Pad Driver Disc and thread into Hub Stud. Tighten securely. Follow these instructions for each disc assembly (refer to figure above).

Install Silabide Pads by pushing the pad against the bristles. The pad should stay on the disc and the surfacer can then be lowered to it's normal position.

When using the surfacer as a scrubber, try not to lift the surfacer from the slab except to remove or change pads. If the pad comes loose from the disc, stop the surfacer and repeat Pad installation from step #1 (disconnect the power source).



# GRINDER/SURFACER ACCESSORIES

## (for the models listed in this manual)

### Dyma-Serts (Patented)

DYMA-SERTS are diamond segments welded to snap-in plates for faster, controlled, dry grinding, and are ideal for removing trowel marks, rough finish, rain spots, large volume projects, paints, thin mastics, epoxy and urethane coatings, or polymer enhanced surfaces. DYMA-SERTS can be used wet or dry and will outperform stones by grinding many times faster, removing tough materials, and lasting many times longer - up to 30,000 sq. ft. (2,800 sq. meters) life (at 1/32") dependent on depth of removal, coatings, speed of operation, matrix, etc. Extra weight can be added to the grinder to increase production. Choose the DYMA-SERT to fit your job.

**EG-1X** General purpose matrix for fast grinding of concrete, thin mastics, paints or urethane and epoxy thin coats.

**EG-2X** Use on abrasive material. Matrix is designed harder for concrete less than 72 hours old, brick or abrasive sands. Grinding will be slower and tool life will be longer.

**EG-3X** Hardest matrix for use on rough surfaces such as epoxy mortars or sharp aggregates (flint, granite, etc.).

NOTE: Dyma-Serts for use on terrazzo are available - call EDCO for additional information.

### Grinding Stones

Grinding Stones are generally used when there is a need to remove trowel marks, rain spots, excess concrete, rough finishes, or high spots less than 1/16" (2mm) in height. A variety of grit sizes are available, beginning with a super course C-10-S to very fine polishing types C-80 and C-120 used to grind terrazzo and marble. The EDCO grinder will remove up to 1/16" (2mm) of concrete at the rate of approximately 500 sq. ft/hr. (46 sq. m/hr.) using grinding stones of the C-10-S grit. Extra weight can be added to the grinder to improve the grinding speed. The hardness of the surface, size of aggregate, age of slab or additives and sealers required to meet surface specifications will affect the grinding speed and rate of removal.

### Industrial Surfacers Discs

Industrial Surfacers Discs with replaceable hi-carbon steel cutters can be used in place of the multi-accessory discs to create a simple, high speed cleaning system and save hours

of hard work, intensive labor when hardened deposits of material such as fiberglass, ice, sugar, rubber, etc., have to be removed from factory floors.

Cutter wheels are easily changed and may be space to fit your particular job. Ideal for use in foundries, sugar refineries, walk-in freezers, mobile home and recreational vehicle manufacturers, rubber tire/hose/belt plants, paint booths, boat/tub/shower manufacturers, steel mills or fabricating plants.

### Silabide Pads

Silabide Pads are special nylon mesh pads impregnated with silicon carbide grit designed for super scrubbing action. Use to remove fins or marks on gyp-crete or other underlayment materials. Remove mildew, rust or discolorations from concrete, clean concrete forms and strip scale and rust from slab steel plate surfaces. Silabide pads can be used with detergents or dry and are attached to the EDCO Grinder with a pad driver assembly.

### Scarifiers (used with "multi-discs")

Scarifiers are used to grind slab surfaces. The action is faster than with grinding stones leaving a "rough sandpaper finish" that may be desirable for non-slip floors, ceramic tile installation or epoxy mortars.

The action of the steel cutter wheels is to "pick" away the concrete from around the aggregates. The cutter will not grind the aggregate, consequently, the aggregate will remain exposed and above the surface of the slab. In some instances the aggregate will loosen or split and break away from the concrete bond. This condition can be controlled and is useful when an exposed aggregate surface is required.

If the desired end result is a smooth, flat surface - use scarifiers first for fast surface removal, then change to coarse grit (C-10-S) grinding stones to bring the high aggregate to the level of the slab.

EDCO offers two (2) models of scarifiers. The standard small cutter wheel assembly has sharp carbon steel cutters suitable for all scarifying applications. Life of this assembly is from 3 to 6 hours depending on the surface material. The heavy duty cutter assembly has an anticipated life from 8 to 20 hours. Action is basically the same as the standard units except cutting life is extended. Use it where changing cutter assemblies often is not convenient.

## PROCEDURE FOR LUBRICATING FLANGE BEARINGS



The procedure is the same for two or four disc machines. The red hood has to be removed to access the grease points on the flange bearings. The single disc grinder is lubricated from the fittings on the exterior of the machine. The grease points are circled in the photos above. There are duplicate grease fittings on the underside of the 2-EC, 2-GC and the 411 models. The skirts will have to be removed to access the grease points.

To grease the flange bearings attach the grease gun to the grease fittings and give only two (2) pumps on the grease gun every 50 hours of use. If excessive over lubrication is done grease will leak onto the work surface causing possible damage and wasted cleanup time.

## PROCEDURE FOR ATTACHING A VACUUM

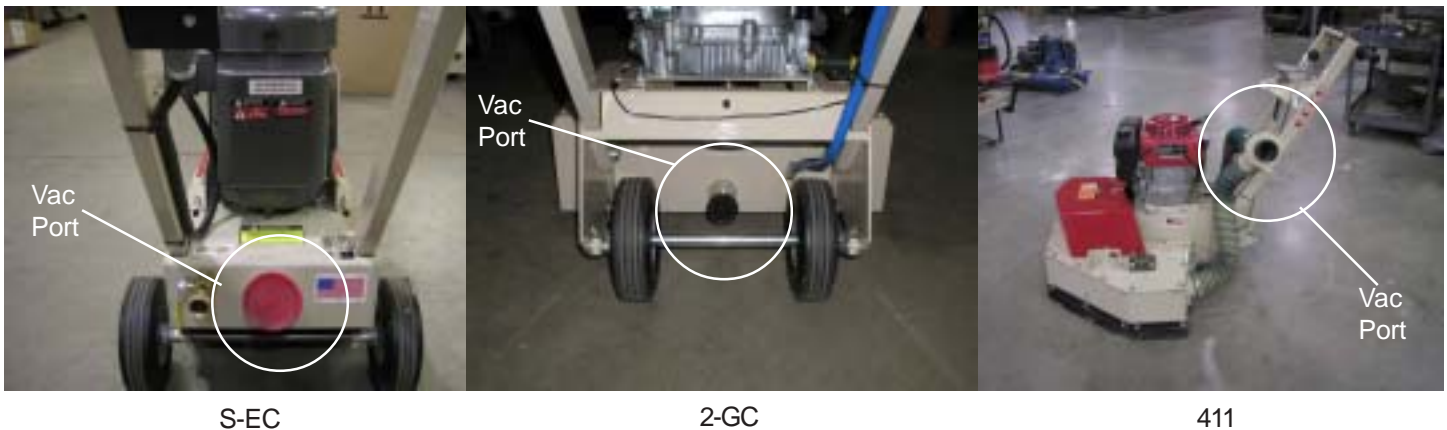

If using a vacuum for dust control attach it to the vacuum port at the rear of the machine except for the 411 which is on the handle as pictured above, securing it with clamps. The ports are circled in the photos above.



# MAINTENANCE INSTRUCTIONS



1. Disconnect the machine from the power source. Remove the spark plug lead on the propane and gasoline engine models or disconnect the supply voltage connector at the machine on electric models before performing any maintenance. All maintenance to be performed by qualified personnel.

2. Never work under equipment without first properly securing the equipment to prevent it from moving or falling. Always work on a flat and level surface.

3. For Propane and Gasoline Models, refer to the engine manual for maintenance information specific to the engine being used.  
 ~Be sure to check oil level before operation (while engine is cold).\*  
 ~Clean air filter element daily.

4. Grease bearings after every 50 hours of use. Refer to **page 13** for lubrication points.\*\*

5. Perform a visual inspection of the entire machine before each operation. Be sure all fasteners are tight and secure, check for signs of metal cracking or fatigue, inspect for damage to electrical wiring, damage to fuel lines, check bearings and inspect to be sure proper guards are in place and secure.

6. Inspect belts before each operation. Check belt tension. On new equipment belts should be re-tensioned after the first few hours of use. Damaged, stretched or excessively worn belts should be replaced with a new *matched set* for maximum power transfer.

To tension belts, loosen engine/motor mounting hardware slightly. Adjust the engine/motor position until the belts are tight. Re-torque the engine/motor mounting hardware, refer to **page 8**.

Proper belt tension must be maintained to transmit the engine/motor power to the grinding disc. Slipping belts will overheat, the disc life will be shortened and the cutting speed limited. Over tensioned belts will shorten the belt and bearing life.

7. Before operation, check Grinding Discs to be sure they are tight. Grinding discs loosen with use. Tighten bolts (4 on each disc) as required.

8. Before operation, check Neoprene bushing for wear and replace as necessary.

9. On gasoline and propane models inspect spark plugs. Clean if dirty, replace if the electrodes are burned. Gap plugs at .020".

\* For Propane Models use a mild detergent motor oil that will not leave ash deposits. "Gas engine oils" are available from major petroleum companies. These "gas engine oils" are specifically blended for long-life on LP-Gas or natural gas engine operation, which will not carbon up the combustion chamber or shorten valve life. Premium oils should not be used in LP-Gas or natural gas engines as the metallic detergents will damage the engine valves.

\*\* Gear Case "A" (refer to figure on page 13 )

The gear case of your EDCO grinder has been pre-lubricated at the factory with approximately 3 pounds of lubriplate, No. 630-2 grease. We recommend it's continued use.

Each grinder has an inspection hole in the gear case top plate to enable you to check the amount of grease in the case. Remove this cover with the end of a screwdriver, if grease is visible do not add any. If you cannot see the grease, add a small amount (1 pound is usually more than enough). Do not overfill. The grease in the gear case should last from three to five years before there is any need to refill or add. (Note: Models SEC/SGC are not gear driven so this does not apply).

Bearings "B" (refer to figure on page 13)

Each grinder has bearings on top and bottom of the machine. All bearings are self-aligning, sealed units equipped with grease fittings. These bearings should be lubricated every 50 hours of operation with Lubriplate No. 630-2, or other good bearing grease. DO NOT over lubricate.

An occasional drop or two of oil on the wheel bearings will help prevent binding.





**Repairs are to be done  
by authorized EDCO  
Dealers only.**

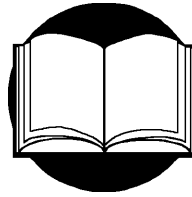

**Read and follow  
instructions in the engine  
owners' manual.**

## Maintenance Schedule

	Before Operation	Every 4 Hours	Daily	Every 50 Hours of Operation	As Required
Visual Inspection of Entire Machine	<b>X</b>				
Check Engine Oil*	<b>X</b>				
Change Engine Oil* (refer to Engine manual)				<b>X</b>	
Clean Air Filter Element*				<b>X</b>	
Grease Bearings				<b>X</b>	
Inspect Drive Belts	<b>X</b>				
Inspect Grinding Discs	<b>X</b>				
Replace Neoprene Rings					<b>X</b>
Belt Tensioning					<b>X</b>
Clean Dust & Dirt Off machine					<b>X</b>

\* Gasoline and Propane Models only



100 Thomas Johnson Drive, Frederick, MD 21702-4600 USA  
 Phone (301) 663-1600 • 1-800-638-3326  
 Fax (301) 663-1607 • 1-800-447-3326  
 Website: [www.edcoinc.com](http://www.edcoinc.com) • Email: [sales@edcoinc.com](mailto:sales@edcoinc.com)

Printed in USA  
 TWW ©2003

# LIMITED EQUIPMENT WARRANTY

Equipment Development Company, Inc. herein referred to as EDCO warrants that each new unit manufactured by EDCO to be free from defects in material and workmanship in normal use and service for a period of (1) one year (except in the case of the cutter drum assembly on all model concrete asphalt planes, in which case the warranty period shall be 90 days) from date of shipment to the original buyer or equipment rental center owner.

EDCO will, at its option, repair or replace, at the EDCO factory or at a point designated by EDCO any part, which shall appear to the satisfaction of EDCO inspection to have been defective in material or workmanship.

This warranty, does not apply to failure occurring as a result of abuse, misuse, negligent repairs, corrosion, erosion, normal wear and tear, alterations or modifications made to the product without express written consent of EDCO: or failure to follow the recommended operating practices and maintenance procedures as provided in the products operating and maintenance manuals.

This warranty does not obligate EDCO to bear any transportation charges in connection with the replacement or repair of defective parts. This warranty does not obligate EDCO to bear any expense for travel time or of personnel in connection with any service calls.

Accessories or equipment furnished and installed on the product by EDCO but manufactured by others, including but not limited to engines, motors, electrical equipment, transmissions, etc., shall carry the accessory manufacturers' own warranty.

**THIS WARRANTY IS IN LIEU OF ALL OTHER WARRANTIES, EXPRESSED OR IMPLIED, OR STATUTORY, INCLUDING ANY WARRANTIES OF MERCHANTABILITY OR OF FITNESS FOR A PARTICULAR PURPOSE.**

## LIABILITY LIMITATIONS

The remedies of the user set forth under provisions of warranty outlined above are the exclusive and total liability of EDCO with the respect to their sale or the equipment and service furnished hereunder, in connection with the performance or breach thereof, or from the sale, delivery, installation, repair or technical direction covered by or furnished under the sale, whether based on contract, warranty, negligence, indemnity, strict liability, or otherwise shall not exceed the purchase price of the unit of equipment upon which such liability is based.

EDCO will not in any event be liable to the user, any successors in interest or any beneficiary or assignee relating to this sale for any consequential, incidental, indirect, special or punitive damages arising out of this sale or any breach thereof, or any defects on, or failure of, or malfunction of the equipment under this sale based upon loss of use, lost profits or revenue, interest, lost goodwill, work stoppage, impairment of other goods, loss by reason of shutdown or non-operation, increased expenses of operation of the equipment, cost of purchase or replacement power of claims of users or customers of the user for service interruption whether or not such loss or damage is based on contract, warranty, negligence, indemnity, strict liability, or otherwise.

EDCO reserves the right to modify, alter and improve any part or parts without incurring any obligation to replace any part or parts previously sold without such modified, altered or improved part or parts.

No person is authorized to give any other warranty or to assume any additional obligation on EDCO's behalf unless made in writing and signed by an officer of EDCO.

Equipment Development Company, Inc.

## USE ONLY GENUINE EDCO PARTS AND ACCESSORIES

For your own safety, the safety of others and the life of your machine

